

Optional Equipment	Note
Eddy current retarder	Standby retarder, suitable for long downhill road conditions
Power battery capacity 528kwh	Suitable for generally flat road conditions
Tilted body	Suitable for materials diameter $\geq 500\text{mm}$
Automatic weighing system	Real-time loaded weight monitoring
Automatic lubrication system	For regular grease filling in a specified amount
360°-imaging camera system	Around view for vehicle safety
A/C with cooling function only	Suitable for tropical regions where no heating is required
Electric lifting of the cab	save time for maintenance and overhaul
Tire model: 16.00R25 E4	Low-speed gravelly condition



HEAVY EQUIPMENT Sp. Z O. O.

Address: UL. MAZOWIECKA 11 /49, 00-052 WARSZAWA,
POLAND UL. KORFANTEGO 138A, 40-156 KATOWICE, POLAND
Tel.: +48 575 156 769, +48 452 900 033
Website: www.hesanyi.com
E-mail: info@hesanyi.com, poland.sanyi@gmail.com

SANY HEAVY EQUIPMENT CO., LTD

Address: 16 Kaifa Road, Economic & Technological Development Zone,
Shenyang, Liaoning Province, P.R.China.
Postal Code: 110027
Official Website: www.sanyglobal.com
E-mail: guanqb@sany.com.cn
Customer Service Hotline | Tel: 0086 - 400 6098 318

Reminder:
Any change in the technical parameters and configuration due to product modification or upgrade may occur without prior notice. The machine in the picture may include additional equipment. This brochure is for reference only, and goods in kind shall prevail. Copyright at SANY. No part of this brochure may be copied or used for any purpose without written approval from SANY.



Nominal Payload
72tonnes/79tons

Gross Vehicle Weight (GVW) up to
112tonnes/123tons

Peak power
740kW

Technical Data

Overall Parameters	Unit	Value
Overall dimensions: L × W × H	mm/in	9,550×3,960×4,250(8,300) /376×156×167(327)
Wheelbase	mm/in	4,075+1,750/160+69
Front track width	mm/in	2,835/112
Rear track width	mm/in	2,859/113
Ground clearance	mm/in	350/14
Min. steering radius	mm/in	12,000/472
Rated power	kW	440
Peak power	kW	740
Power battery	kWh	396
Charging time	h	1
endurance mileage	km	≥160(heavy loaded)
Max. Gradeability	%	38
Struck SAE	m ³ /yd ³	38/50
Heaped SAE 2:1	m ³ /yd ³	45/59

Weight Distribution

Axle Capacity	Front Axle	Rear Axle
Unloaded	37%	63%
Loaded	20%	80%

Overall Dimensions

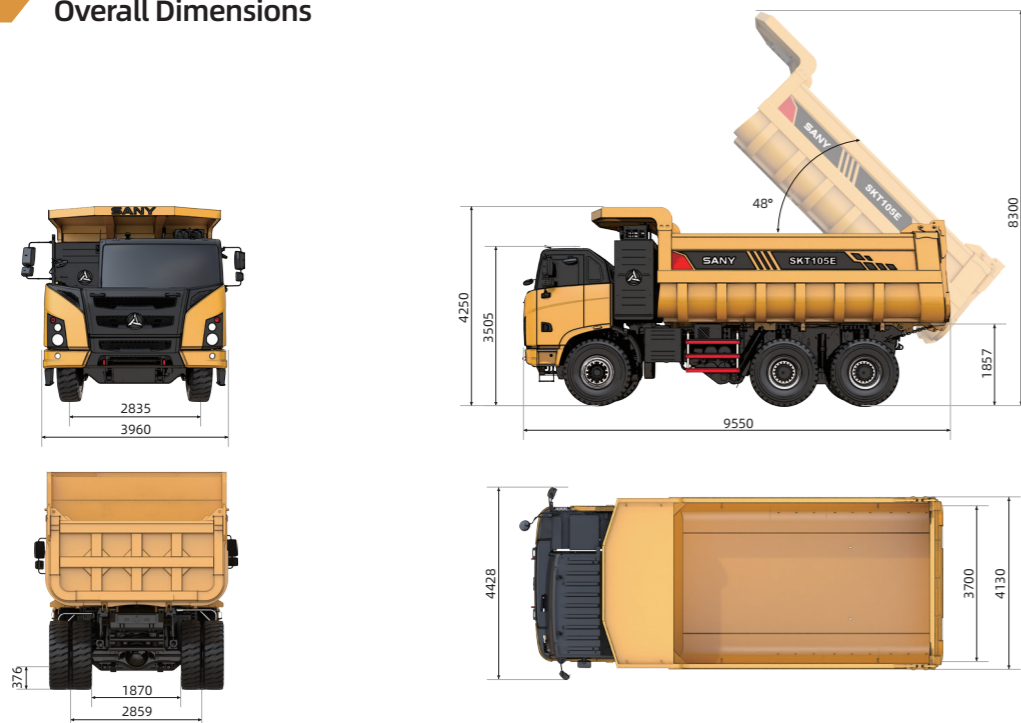

尺寸单位: mm
* 具体参数以实际为准

Fluid Capacities

Fluid Capacities	L
Hydraulic oil tank (hydraulic oil)	240
Motor cooling system (antifreeze)	25
Battery cooling system (antifreeze)	19
Transmission (automatic transmission oil)	17
Front suspension (hydraulic oil)	1.75×2
Rear suspension (hydraulic oil)	1.75×4
Intermediate-axle main reducer (gear oil)	21
Rear-axle main reducer (gear oil)	21

Weight Parameters

Item	kg	lb
Net weight	40,000	88,185
Rated payload	70,000	158,733
Max. gross weight	110,000	246,918

* The maximum gross vehicle weight (GVW) includes optional equipment, all accessories, fully filled fuel tank, loadings, etc.; Overload will seriously deteriorate the lives of the components and the truck!

Main Configurations

Motor × 2

- Model: EM230-230H46;
- Type: Permanent magnet synchronous motor;
- Continuous/peak power: 440/740kW;
- Continuous/peak torque: 1150/2100Nm.

Transmission × 2

- Model: DET6S360;
- Type: double 3-gear AMT;
- Maximum output torque: 21000Nm;
- Gear ratio: 7.233/3.048/1.415;
4.667/2.064/1.

Power battery

- Model: lithium iron phosphate;
- Battery capacity: 396kWh;
- Charging time: 1h(SOC 25%-95%);
- High density lithium iron phosphate battery designed for mining area, featuring high safety and extended cycle life. The battery pack is made of customized extruded aluminum casing, which greatly improves the vibration-proof performance; 5 years ultra-long warranty.

Brakes

- Single-axle 90000Nm high-torque brake;
- Regenerative braking retardation, which meets 25kph constant speed retarding in 10% heavy duty downhill conditions;
- Equipped with standby eddy current retarder to effectively cope with extreme working conditions;
- Overall braking performance improved by 23% and brake shoe wear reduced by 50%.

Cab

- FOPS/ROPS certified. Equipped with integral four-pillar tipping protection design, adjustable cushioned seat, luxury upholstery, and tiltable and telescopic steering wheel to provide a comfortable operating space;
- The cab conforms to the requirements of ISO 3471. The cab provides a sound exposure Leq (equivalent sound level) of less than 78 dB(A) when tested with doors and windows closed.

Steering

- Full-hydraulic emergency steering: improving driving comfort, steering agility, and reliability;
- In the event of loss of engine power, it provides emergency power to system for steering.

Frame

- The antitorque frame welded from high strength alloy steel plate with steel castings. It features better bending resistance, antitorque and impact resistance.
- Overload capacity > 20%, stiffness lifting > 25%, frame life > 10 years.

Suspension

- Vibration isolation rate is increased by more than 30%, with more driving comfort, and protecting the carrier frame and axle
- Bench durability test qualified. Service life surpasses 10 years.
- Completely solve the problem of leaf spring breakage and tire slippage in the industry.
- Front suspension stroke: 220mm(8.7in);
- Rear suspension stroke: 250mm(9.8in).

Hoist

- High-pressure and large-displacement plunger pump, with lifting efficiency increased by 30%.
- Double cylinder lifting ensures safer and more stable lifting.
- Body hydraulic pump flow rate: 225L/min;
- Liftings 22s, Lowerings 30s.

Drive Axle

- Heavy load type, full floating axle shaft, compact structure and large transmission torque of final drive, with reinforced planetary wheel reducer and high-strength cast steel axle housing;
- Rear axle speed ratio: 16.64.

Body

- The body is newly designed U-shape structure. The arc-shape side plates have better impact resistance and wear resistance, which guarantees smooth dumping without material stuck, pulling through body structure, higher tilted angle 48°. The standard body is made of welded 14mm bottom plate, 10mm side plate, and 10mm front plate;
- Struck (SAE std): 38m³(50yd³);
- Heaped 2: 1 (SAE std): 45m³(59yd³).

Tires

- Standard: 16.00R25 E3;
- Specification of wheel rim: R25;
- Under certain working conditions, TKPH(ton-Km/h) capabilities of standard tires could be exceeded. Please kindly consult tire manufacturers for optimum tire selection.